

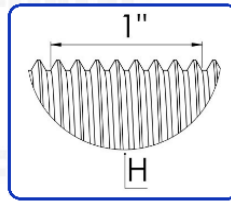

FIJATEC

ASME B18.2.2

TUERCA HEXAGONAL 2H

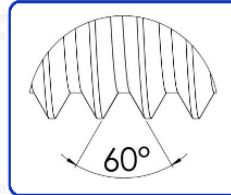
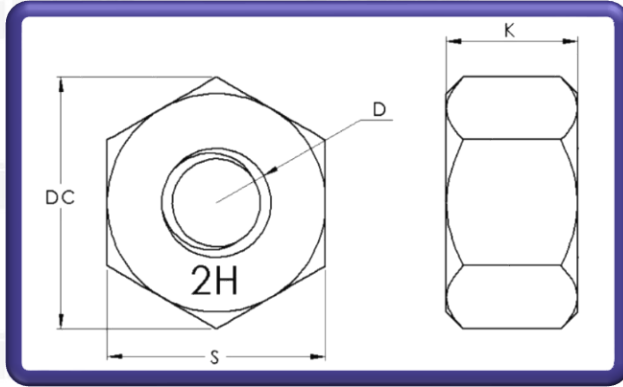

Diámetro nominal -D-	Altura -K-	Llave -S-	Distancia entre esquinas -DC-	Hilos por pulgada -H-	
				UNC	UNF
1/2"	1/2"	7/8"	1"	13	20
5/8"	5/8"	1-1/16"	1-7/32"	11	18
3/4"	3/4"	1-1/4"	1-7/16"	10	16
7/8"	7/8"	1-7/16"	1-21/32"	9	14
1"	1"	1-5/8"	1-7/8"	8	14
1-1/8"	1-1/8"	1-13/16"	2-1/16"	7	12
1-1/4"	1-1/4"	2"	2-1/4"	7	12
1-3/8"	1-3/8"	2-3/16"	2-1/2"	6	12
1-1/2"	1-1/2"	2-3/8"	2-11/16"	6	12
1-5/8"	1-5/8"	2-9/16"	2-15/16"	5	12
1-3/4"	1-3/4"	2-3/4"	3-1/8"	5	12
1-7/8"	1-7/8"	2-15/16"	3-5/16"	4.5	12
2"	2"	3-1/8"	3-1/2"	4.5	12
2-1/4"	2-1/4"	3-1/2"	3-15/16"	4.5	12
2-1/2"	2-1/2"	3-7/8"	4-3/8"	4	12
2-3/4"	2-3/4"	4-1/4"	4-13/16"	4	12
3"	3"	4-5/8"	5-1/4"	4	12

fijatec.com



Azcapotzalco (55) 5561-7279

Vallejo (55) 5367-2424